

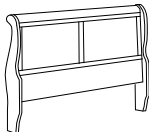

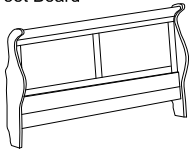
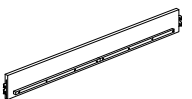

ASSEMBLY INSTRUCTIONS

MODEL : IDB03 QUEEN BED		
NO.	PART LIST	QTY
A	Head Board 	1 PC
B	Foot Board 	1 PC
C	Side Rail 	2 PCS
D	Bottom Rail 	3 PCS
E	Bottom Rail Support 	3 PCS
NO.	HARDWARE LIST	QTY
F	CSK SCREW M4 x 32mm 	6 PCS
G	CSK SCREW M4 x 16mm 	16 PCS
H	Bracket 	4 PCS

STEP 1 : Attach Side Rail (C) to Head Board (A) Closely and push down to fit it. Repeat the same step to fitting the Foot Board (B).

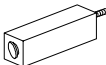

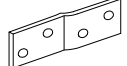
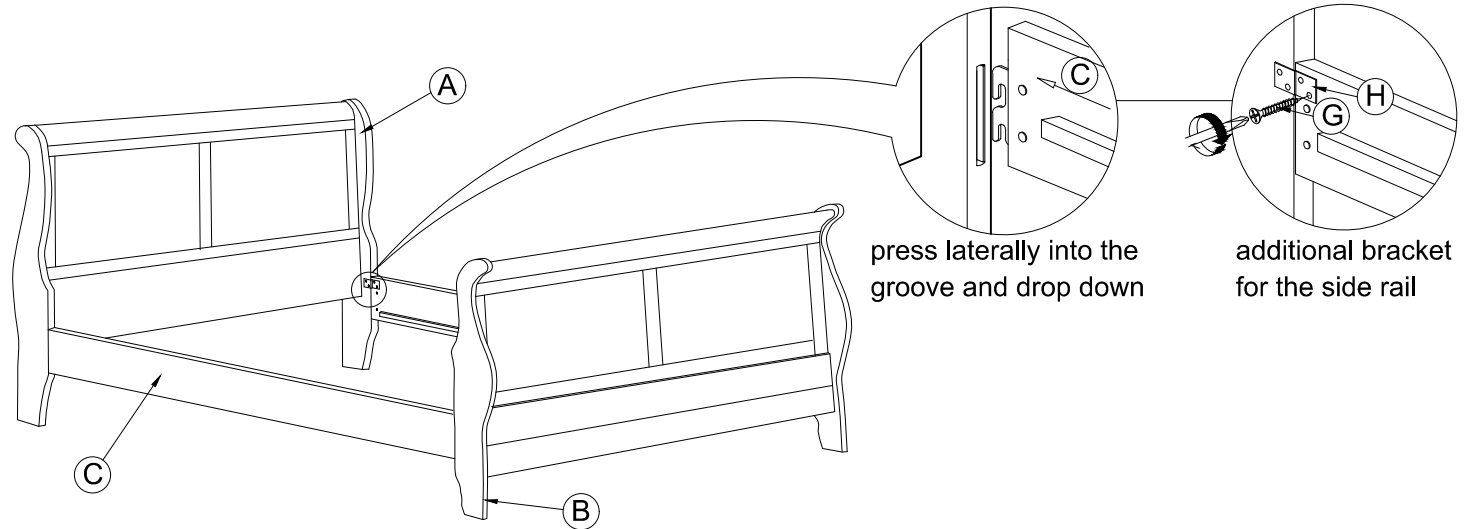
STEP 2 : Fix the Bottom Rail Support (E) with Adjuster to Bottom Rail (D). Attach the assembled Bottom Rail (D) to Side Rail (C) as picture shown. Loosen and tighten Adjuster for the stability of bed. Lastly, tighten the Bottom Rail (D) with CSK Screw (F).
(NOTE : THE SETUP MUST DONE AT THE DECIDED LOCATION FOR THE BED TO OBTAIN PERFECT STABILITY)

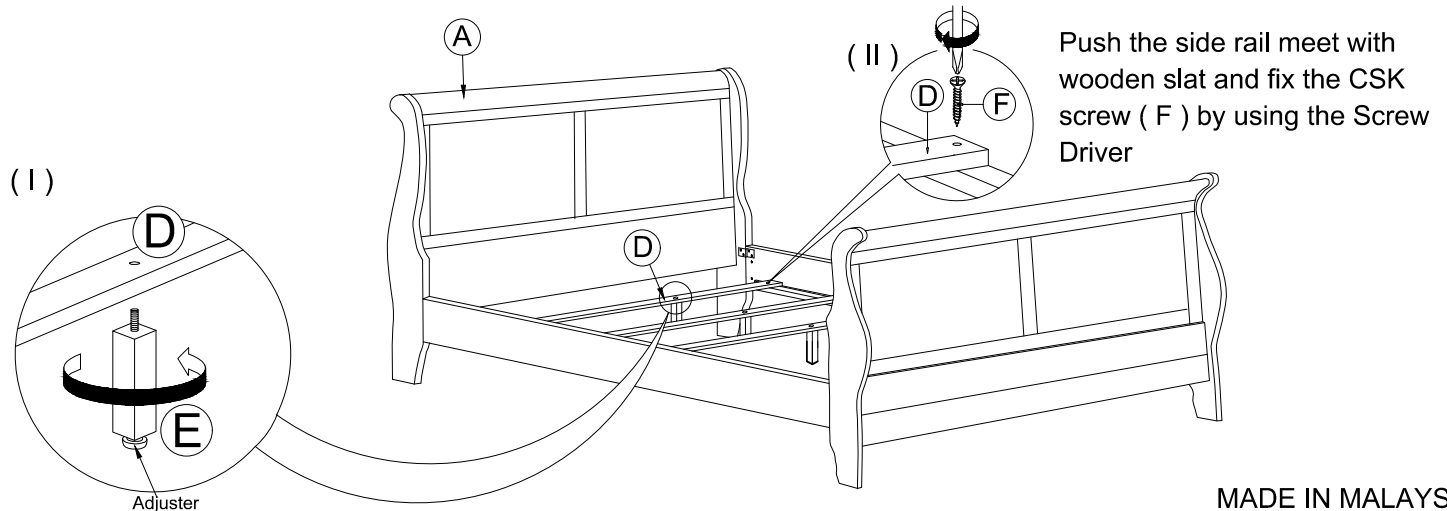

MADE IN MALAYSIA

NOTE : MUST TIGHTEN SCREWS PERIODICALLY WITH USE SCREW WILL BECOME LOOSE, CHECK TIGHTNESS OF ALL SCREW EVERY 6-8 WEEKS